

# HURRICANE RESISTANT BUILDINGS

*Building CAT-5 Resistant Timber Roofs*



---

*An Illustrated Guide for Builders*

---

**PAHO**



Pan American  
Health  
Organization



World Health  
Organization  
REGIONAL OFFICE FOR THE  
Americas

July 2021

## Acknowledgements

Primary author	Eng. Shalini Jagnarine
Contributor & Illustrator	Eng. Gisell Alban
Contributor	Dr. Dana van Alphen
Contributor	Eng. Marie-Terese Louis
Peer reviewer	Hon. Tony Gibbs
Peer reviewer	Eng. Clifford Murray
Reviewer	Eng. Alfrico Adams
Reviewer	Clemens Buter
Editor	Patricia Bittner

## Contents

Chapter 1 Introduction .....	5
Context: Who is it for and when to use it? .....	5
Scope: What is contained in this Guide? .....	5
Building geometry constraints of this guide .....	6
Key: How to use this guide.....	6
Chapter 2 Building performance.....	7
Building geometry.....	7
Chapter 3 Building Components .....	9
Roof components.....	9
Walls (Masonry walls) .....	9
Chapter 4 Roofs to Resist Category 5 Hurricanes .....	10
Buildings in Exposure B .....	12
Buildings in Exposure C .....	15
Buildings in Exposure D.....	18
Chapter 5 Timber Roof Connectors .....	20
Examples of types of connectors .....	21
Prescriptive connectors .....	22
Rafter Connectors .....	24
Truss/Rafter to Masonry/Concrete.....	25
Hip Rafter to Wall Connector.....	25
Rafter Connectors .....	26
Chapter 6 Roof Sheeting .....	27
Roof sheets .....	27

Roofing screws .....	28
Chapter 7 Quality Control Checklist.....	30
Bibliography .....	32
Annex 1 – Wind Speeds .....	33
Annex 2 – List of Hardwoods and Softwoods .....	37
Annex 3 – Sample Calculation.....	38

## Chapter 1 Introduction

The year 2020 set a record for the highest number of tropical/subtropical storms registered in a year. According to data from the National Oceanic and Atmospheric Administration (NOAA), the 2020 Atlantic Hurricane Season was the busiest year, with 29 events that caused economic losses estimated at USD 50 billion, according to data from AON.(1) Climate change has also brought with it an increased risk of the impact of higher intensity storms.(2) The rise in water temperature in the Atlantic is causing a greater chance for hurricanes to develop. These natural events are not only more frequent but, in some cases, more catastrophic as well.

One major impediment to resilience is the lack of suitably qualified or experienced professionals to design and build hurricane-resistant buildings in many countries that are typically the most affected. In most developing countries, current building codes do not encourage the construction of robust structures that will withstand major hurricanes nor are the building codes enforced. Additionally, reconstruction after the impact of such events is often rushed and poorly designed and executed.

The Pan American Health Organization (PAHO) aims to reduce the recurrent damage following the impact of major hurricanes, with this illustrated, easy-to-follow guide to build Category 5-resistant roofs and external walls.

### Context: Who this guide is for and when to use it

These guidelines are to be used by local builders and laymen for the safe design and construction of roofs in hurricane-prone regions. True sustainability is achieved once people understand what they can do to help themselves and prevent future damage and losses. Therefore, we aim to provide graphic tools illustrating the safe and proper way to build and connect timber roofs to help minimize the loss of building infrastructure, impact on livelihoods and loss of lives.

### Scope: What is contained in this Guide?

Gable or Hip Roofs: recommended sizing and spacing of the timber structure.

Many buildings, including essential facilities such as health centres and shelters, are often built without the input from qualified structural engineers, designers, and builders. This guide provides detailed illustrations and information on the sizing of typical components for timber roofs which are resilient to wind speeds equivalent to Category 5 Hurricanes<sup>1</sup>.

Minimum typical detailing for external concrete block walls is also included as the support structure for the timber roof.

---

<sup>1</sup> Category 5 Hurricane, according to the Saffir-Simpson scale, has minimum 3-second gust wind speeds of 173 mph or 77m/s over land.

## Building geometry constraints of this Guide

This guide can be used for buildings in general, as long they comply with the following dimensions:

- Maximum building width: 60 feet or 18.3 metres
- Maximum building length: 80 feet or 24.4 metres
- Maximum mean roof height: 33 feet or 10 metres. Buildings that are 1-storey to 3-storeys high
- Minimum roof pitch: 20 degrees

The information in this guide pertains to buildings that are either partially or fully enclosed in the event of a storm or hurricane. This means that the windows and doors should be fully closed to prevent wind or driving rain from causing damage to the interior furnishings and finishes of the building.

The guide is applicable to pitched roofs that are either hip or gable, as illustrated below:

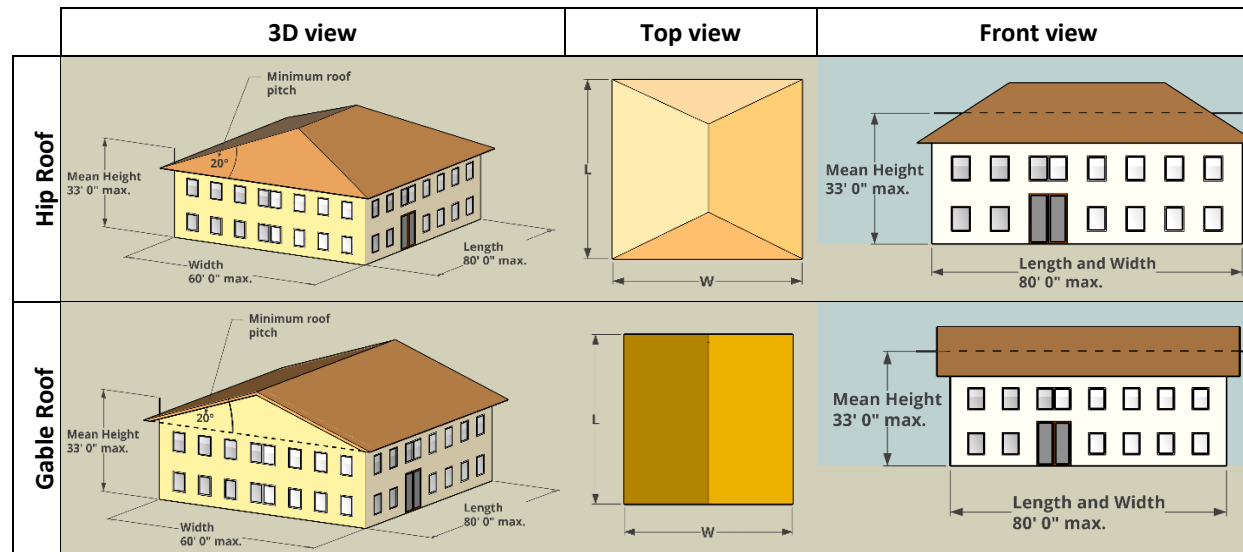

## Key: How to use this Guide

This Guide is divided into 7 chapters. Chapters 1- 3 provide an introduction on buildings, the performance of different buildings according to their geometry, and the components of roofs and walls for the reader's reference. Chapter 5 contains illustrations of typical timber connectors, which should be installed at every timber joint or intersection. Chapter 6 contains useful information on roof sheeting and roofing screws. Chapter 7 comprises a simple Checklist that should be followed for timber roofs.

Chapter 4 contains practical design information to determine the maximum spacing of different standard sizes of timber roof members. It includes the roof components sizing and configuration. To find out which configuration/sub chapter applies to you, follow these steps:

1. Determine which exposure category your building falls into:
  - a. Exposure B refers to an urban or suburban location or a downtown location.
  - b. Exposure C refers to open country or grasslands.
  - c. Exposure D refers to flat unobstructed site facing a large water body.
2. Determine what is your roof type. This guide contains two types: gable or hip.
3. Determine the maximum spacing of the timber rafters and purlins in imperial or metric units for three standard timber sizes. Each table represents a maximum building width and includes two types of timber: hardwood or softwood.

## Chapter 2 Building Performance

### Building geometry

The illustrations below highlight safe, robust building shapes that are resilient (✓), that is, inherently able to withstand many of the forces that impact them, versus shapes that may be more susceptible to damage (✗) when impacted by events such as hurricanes and earthquakes.

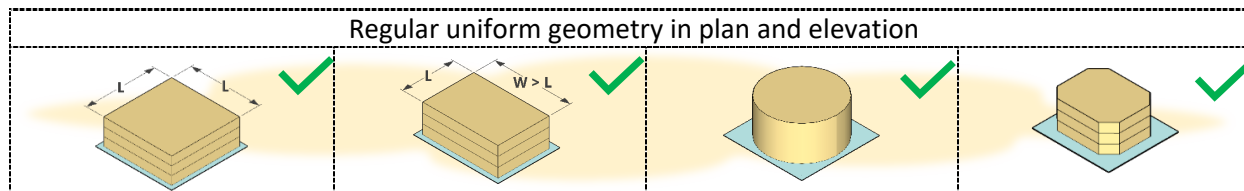

Figure 1 (above)- Regular geometric shapes are recommended.

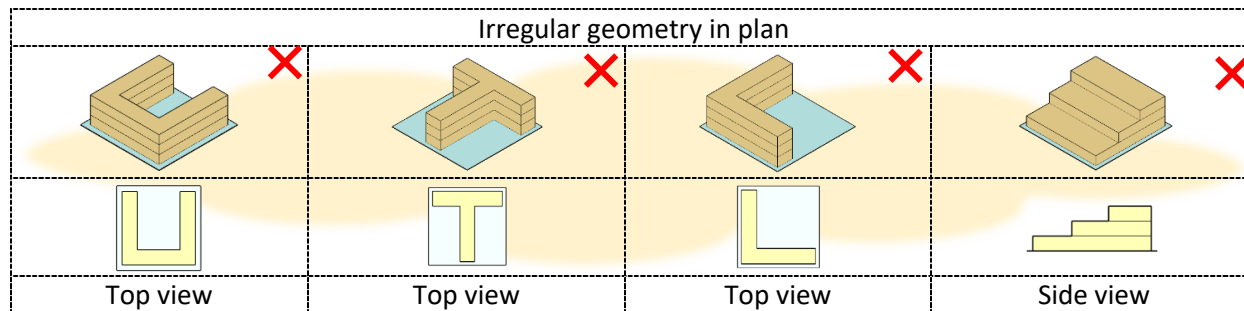

Figure 2. Irregular plan geometries are more prone to damage.



Irregular geometry in elevation		
		
		
Buildings on hillsides with tall slender columns on lower levels	Taller ground floor, such as buildings with shops on the ground floor	Taller middle floor

Figure 3.- Irregular geometries in elevation are also more prone to damage.

Irregular shapes can be made regular by having separation joints between regular shapes		
		
		

Figure 4. Breaking up of irregular geometry to make it regular.

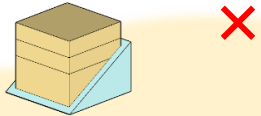
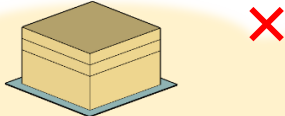
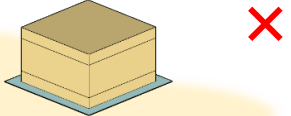

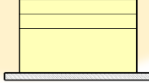
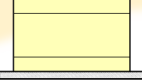
## Chapter 3 Building Components

### Roof components

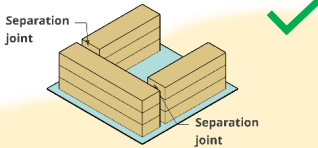
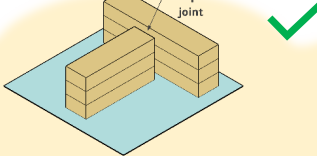
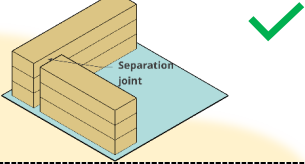
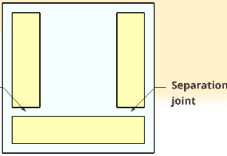
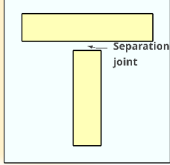
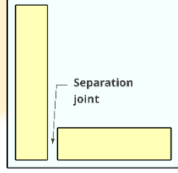
For reference, Figure 5 illustrates the main roof components that will be mentioned in the following sections of this guideline.

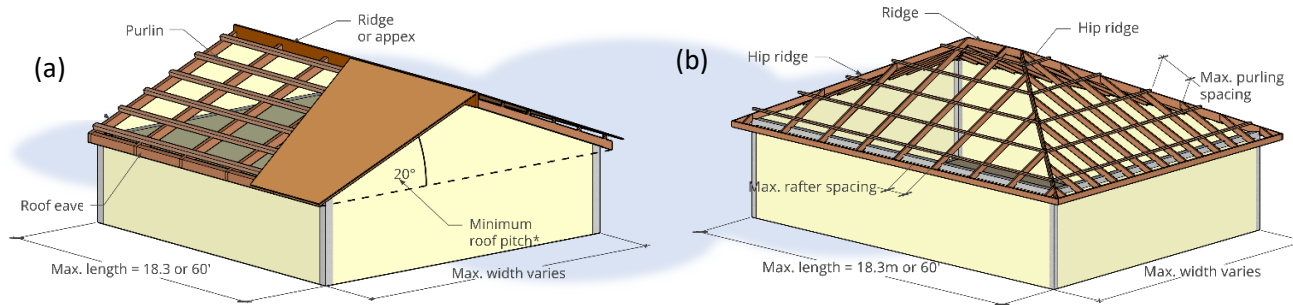

Figure 5 Roof components and minimum roof pitch for (a) gable roofs and (b) hip roofs.

\* The steeper the roof, the better it will resist high winds.

In this document, a minimum roof pitch of 20° is considered for gable roofs and 22.6° for hip roofs. The main timber structural members are considered, that is, the rafters and purlins.

### Walls (masonry walls)

This guideline considers 6" (150mm) wide block walls as the minimum external wall thickness. Walls need to be reinforced horizontally and vertically to increase the resistance to high winds and earthquakes. At a minimum, the horizontal reinforcement should be steel reinforcing bars inserted every third block course, and the vertical reinforcement is a steel bar inserted every second core (the hollow pockets of the concrete block) and filled with concrete or cement grout for keeping the steel bar in place, as shown in illustration (a). Illustration (b) shows the reinforced concrete (RC) beams over the gable end walls, also called the capping beam. The ring beam is the horizontal beam that forms a ring around the building. The reinforced concrete columns frame the corners of the block walls, provide resistance and support for the walls and roof. The lintel beams provide support around door and window openings.

(a)

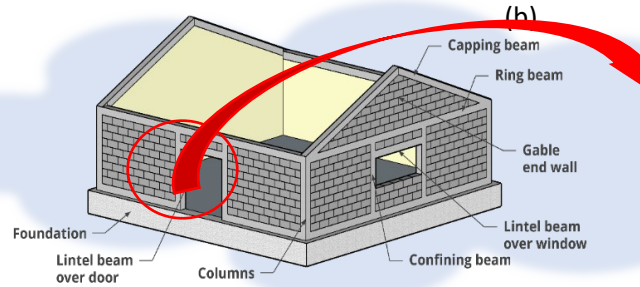

(b)

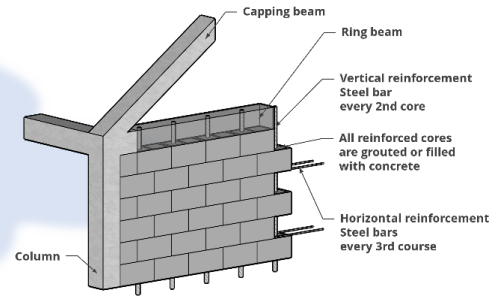

Figure 6 (a) typical minimum framing structural frame components of concrete block masonry walls and (b) typical reinforcement for portion of wall

It is recommended that a certified structural engineer advise on the correct reinforcement requirements for the structural walls, beams, columns, and foundation.

**Note:** Confining the block walls in RC beams and columns makes them more resistant to failure in earthquakes or hurricanes.

## Chapter 4 Roofs to Resist Category 5 Hurricanes

This chapter presents the design of lightweight timber roofs to resist Category 5 Hurricanes. Follow the four steps listed below to design your roof(3).

### Step 1 – Select the Exposure Category based on your building’s location.

Each table represents one of three different geographic locations (based on building codes<sup>3</sup>) referred to as ‘Exposure Categories.’ These three categories are as follows:

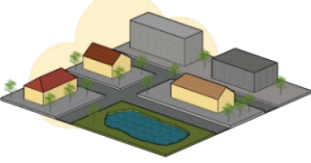
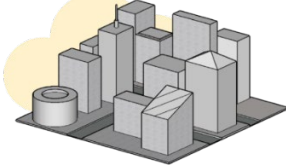
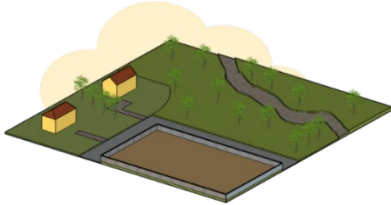
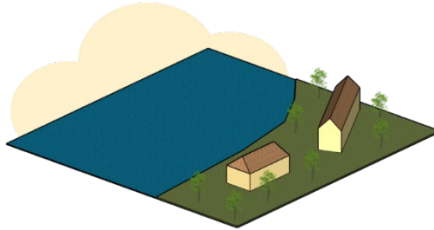
Exposure Category B	Exposure Category C	Exposure Category D
<p>Building location:</p>   <p>An urban or suburban location or a downtown location</p>	<p>Building location:</p>  <p>Open country or grasslands</p>	<p>Building location:</p>  <p>A flat unobstructed site facing a large water body.</p>

**Step 2 – Select your roof type (shape).**

Each table represents one of two different types of roof types/shapes:

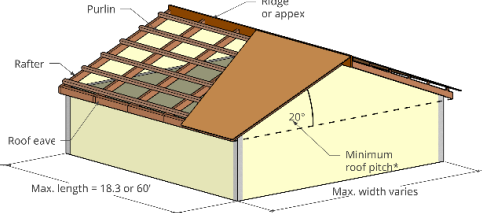
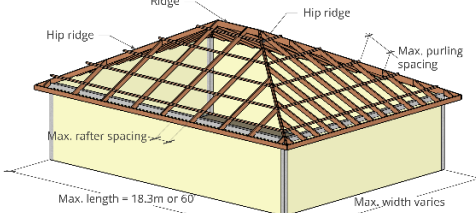
Roof type: Gable	Roof type: Hip
<p>Building geometry:</p> 	<p>Building geometry:</p> 

**Step 3 – Select the maximum width of your building.**

Two maximum widths are presented in each table: 15.3m or 50-feet, and 18.3m or 60-feet.

**Step 4 – Select the type of lumber or wood material to be used.**

Two types of wood are presented. Each table represents either softwoods of pine or cedar, or hardwoods of oak and maple. Refer to Annex 2 for the specific list of types of woods.

**Buildings in Exposure B**

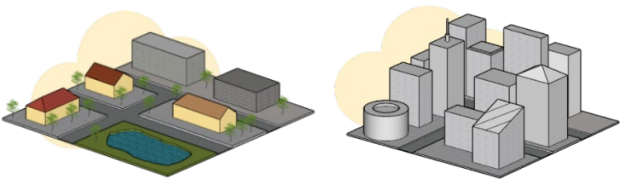
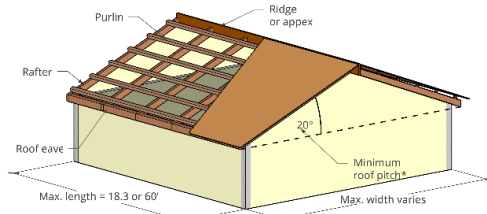
Exposure Category B	Roof type: Gable
Wind speed: 180 mph (80.5 m/s) 3-sec gust over land.	
Building location:  <p>An urban or suburban location or a downtown location</p>	Building geometry: 

Maximum spacing for rafters based on different typical sizes are indicated in the tables below. Hardwoods and softwoods are shown in separate tables. Refer to Annex 2 for the list of suitable types of wood considered in this design. The purlins, for the typical timber roof framing for a gable roof, are considered to have a standard size of 50mm x 50mm (2" x 2") at a maximum spacing of 1000mm (3'-0"). Each purlin connection to rafter carries an uplift force of 0.8kN or 180lbs.

**Applicable for buildings with a maximum width of 15.3m. (Metric units)**

Softwood: Pines and Cedars				
	Maximum allowable rafter spacing (mm)		Uplift forces at connections (kN)	
Rafter sizes (mm)	Higher strength	Lower strength	Higher strength	Lower strength
150 x 50	450	360*	2.60	2.08
200 x 50	790	630	4.57	3.64
250 x 50	1230	980	7.11	5.66

Hardwood: Maples or Oak				
	Maximum allowable rafter spacing (mm)		Uplift forces at connections (kN)	
Rafter sizes (mm)	Higher strength	Lower strength	Higher strength	Lower strength
150 x 50	600	490	3.47	2.83
200 x 50	1050	860	6.07	4.97
250 x 50	1630	1330	9.42	7.69

**Applicable for buildings with a maximum width of 50'. (Imperial units)**

Softwood: Pines and Cedars				
	Maximum allowable rafter spacing (in)		Uplift forces at connections (lbs)	
Rafter sizes (in)	Higher strength	Lower strength	Higher strength	Lower strength
6 x 2	18	14*	584	468
8 x 2	31	25	1027	818
10 x 2	48	39	1598	1272

Hardwood: Maples or Oak				
	Maximum allowable rafter spacing (in)		Uplift forces at connections (lbs)	
Rafter sizes (in)	Higher strength	Lower strength	Higher strength	Lower strength
6 x 2	24	19	780	636
8 x 2	41	34	1365	1117
10 x 2	64	52	2118	1729

**Applicable for buildings with a maximum width of 18.3m. (Metric units)**

Softwood: Pines and Cedars				
	Maximum allowable rafter spacing (mm)		Uplift forces at connections (kN)	
Rafter sizes (mm)	Higher strength	Lower strength	Higher strength	Lower strength
150 x 50	310	250*	2.14	1.73
200 x 50	550	440	3.8	3.04
250 x 50	860	680	5.94	4.70

Hardwood: Maples or Oak				
	Maximum allowable rafter spacing (mm)		Uplift forces at connections (kN)	
Rafter sizes (mm)	Higher strength	Lower strength	Higher strength	Lower strength
150 x 50	420	340*	2.9	2.35
200 x 50	730	600	5.05	4.15
250 x 50	1140	930	7.88	6.43

**Applicable for buildings with a maximum width of 60'. (Imperial units)**

Softwood: Pines and Cedars				
	Maximum allowable rafter spacing (in)		Uplift forces at connections (lbs)	
Rafter sizes (in)	Higher strength	Lower strength	Higher strength	Lower strength
6 x 2	12	10*	481	389
8 x 2	22	17	854	683
10 x 2	34	27	1335	1057

Hardwood: Maples or Oak				
	Maximum allowable rafter spacing (in)		Uplift forces at connections (lbs)	
Rafter sizes (in)	Higher strength	Lower strength	Higher strength	Lower strength
6 x 2	17	13*	652	528
8 x 2	29	24	1135	933
10 x 2	45	37	1771	1445

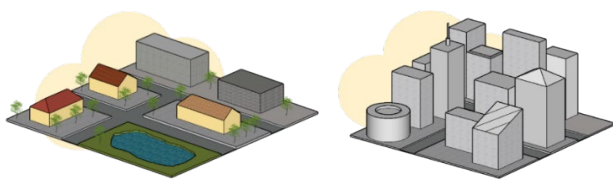
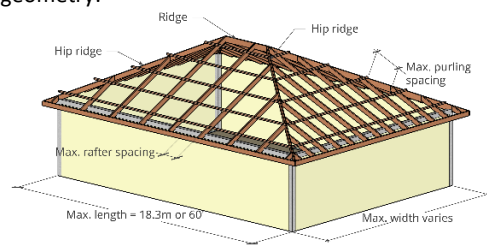
Exposure Category B	Roof type: Hip
Wind speed: 180 mph (80.5 m/s) 3-sec gust over land.	
<p>Building location:</p>  <p>An urban or suburban location or a downtown location</p>	<p>Building geometry:</p> 

Maximum spacing for rafters based on different typical sizes are indicated in the tables below. Hardwoods and Softwoods are shown in separate tables. Refer to Annex 2 for the list of suitable types of wood considered in this design. The purlins, for the typical timber roof framing for a gable roof, are considered to have a standard size of 50mm x 50mm (2" x 2") at a maximum spacing of 915mm (3'-0"). Each purlin connection to rafter carries an uplift force of 0.8kN or 180lbs.

**Applicable for buildings with a maximum width of 15.3m. (Metric units)**

Softwood: Pines and Cedars				
	Maximum allowable rafter spacing (mm)		Uplift forces at connections (kN)	
Rafter sizes (mm)	Higher strength	Lower strength	Higher strength	Lower strength
150 x 50	540	430*	2.58	2.05
200 x 50	950	760	4.53	3.63
250 x 50	1460	1100	6.97	5.25

Hardwood: Maples or Oak				
	Maximum allowable rafter spacing (mm)		Uplift forces at connections (kN)	
Rafter sizes (mm)	Higher strength	Lower strength	Higher strength	Lower strength
150 x 50	710	580	3.39	2.77
200 x 50	1250	1000	5.96	4.77
250 x 50	1900	1580	9.07	7.54

**Applicable for buildings with a maximum width of 50'. (Imperial units)**

Softwood: Pines and Cedars				
	Maximum allowable rafter spacing (in)		Uplift forces at connections (lbs)	
Rafter sizes (in)	Higher strength	Lower strength	Higher strength	Lower strength
6 x 2	21	17*	580	461
8 x 2	37	30	1018	816
10 x 2	57	43	1567	1180

Hardwood: Maples or Oak				
	Maximum allowable rafter spacing (in)		Uplift forces at connections (lbs)	
Rafter sizes (in)	Higher strength	Lower strength	Higher strength	Lower strength
6 x 2	28	23	762	623
8 x 2	49	39	1340	1072
10 x 2	75	62	2039	1695

**Applicable for buildings with a maximum width of 18.3m. (Metric units)**

Softwood: Pines and Cedars				
	Maximum allowable rafter spacing (mm)		Uplift forces at connections (kN)	
Rafter sizes (mm)	Higher strength	Lower strength	Higher strength	Lower strength
150 x 50	370	300*	2.11	1.71
200 x 50	660	530	3.77	3.02
250 x 50	1000	820	5.71	4.68

Hardwood: Maples or Oak				
	Maximum allowable rafter spacing (mm)		Uplift forces at connections (kN)	
Rafter sizes (mm)	Higher strength	Lower strength	Higher strength	Lower strength
150 x 50	500	400*	2.85	2.28
200 x 50	880	710	5.02	4.05
250 x 50	1350	1100	7.70	6.28

**Applicable for buildings with a maximum width of 60'. (Imperial units)**

Softwood: Pines and Cedars				
	Maximum allowable rafter spacing (in)		Uplift forces at connections (lbs)	
Rafter sizes (in)	Higher strength	Lower strength	Higher strength	Lower strength
6 x 2	15	12*	474	384
8 x 2	26	21	847	679
10 x 2	39	32	1284	1052

Hardwood: Maples or Oak				
	Maximum allowable rafter spacing (in)		Uplift forces at connections (lbs)	
Rafter sizes (in)	Higher strength	Lower strength	Higher strength	Lower strength
6 x 2	20	16*	641	513
8 x 2	35	28	1128	910
10 x 2	53	43	1731	1412

## Buildings in Exposure C

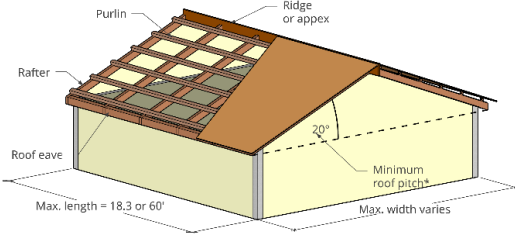
Exposure Category C	Roof type: Gable
Wind speed: 180 mph (80.5 m/s) 3-sec gust over land.	
Building location:  <p style="text-align: center;">Open country or grasslands</p>	Building geometry: 

Maximum spacing for rafters based on different typical sizes are indicated in the tables below. Hardwoods and Softwoods are shown in separate tables. Refer to Annex 2 for the list of suitable types of wood considered in this design. The purlins, for the typical timber roof framing for a gable roof, are considered to have a standard size of 50mm x 50mm (2" x 2") at a maximum spacing of 915mm (3'-0"). Each purlin connection to rafter carries an uplift force of 0.8kN or 180lbs.

### Applicable for buildings with a maximum width of 15.3m. (Metric units)

Softwood: Pines and Cedars				
	Maximum allowable rafter spacing (mm)		Uplift forces at connections (kN)	
Rafter sizes (mm)	Higher strength	Lower strength	Higher strength	Lower strength
150 x 50	310	240*	2.62	2.03
200 x 50	540	430*	4.57	3.64
250 x 50	840	670	7.10	5.67

Hardwood: Maples or Oak				
	Maximum allowable rafter spacing (mm)		Uplift forces at connections (kN)	
Rafter sizes (mm)	Higher strength	Lower strength	Higher strength	Lower strength
150 x 50	410	330*	3.47	2.79
200 x 50	720	590	6.09	4.99
250 x 50	1110	910	9.39	7.7

### Applicable for buildings with a maximum width of 50'. (Imperial units)

Softwood: Pines and Cedars				
	Maximum allowable rafter spacing (in)		Uplift forces at connections (lbs)	
Rafter sizes (in)	Higher strength	Lower strength	Higher strength	Lower strength
6 x 2	12	9*	589	456
8 x 2	21	17*	1027	818
10 x 2	33	26	1596	1275

Hardwood: Maples or Oak				
	Maximum allowable rafter spacing (in)		Uplift forces at connections (lbs)	
Rafter sizes (in)	Higher strength	Lower strength	Higher strength	Lower strength
6 x 2	16	13*	780	627
8 x 2	28	23	1369	1122
10 x 2	44	36	2111	1731

Applicable for buildings with a maximum width of 18.3m. (Metric units)

Softwood: Pines and Cedars				
Rafter sizes (mm)	Maximum allowable rafter spacing (mm)		Uplift forces at connections kN [lbs]	
	Higher strength	Lower strength	Higher strength	Lower strength
150 x 50	210	170*	2.12	1.72
200 x 50	380	300*	3.84	3.03
250 x 50	580	470	5.87	4.75

Hardwood: Maples or Oak				
Rafter sizes (mm)	Maximum allowable rafter spacing (mm)		Uplift forces at connections kN [lbs]	
	Higher strength	Lower strength	Higher strength	Lower strength
150 x 50	280	230*	2.83	2.33
200 x 50	500	410*	5.06	5.06
250 x 50	770	630	7.79	7.79

Applicable for buildings with a maximum width of 60'. (Imperial units)

Softwood: Pines and Cedars				
Rafter sizes (in)	Maximum allowable rafter spacing (in)		Uplift forces at connections (lbs)	
	Higher strength	Lower strength	Higher strength	Lower strength
6 x 2	8	7*	477	387
8 x 2	15	12*	863	681
10 x 2	23	19	1320	1068

Hardwood: Maples or Oak				
Rafter sizes (in)	Maximum allowable rafter spacing (in)		Uplift forces at connections (lbs)	
	Higher strength	Lower strength	Higher strength	Lower strength
6 x 2	11	9*	636	524
8 x 2	20	16*	1137	933
10 x 2	30	25	1751	1432

Exposure Category C

Roof type: Hip

Wind speed: 180 mph (80.5 m/s) 3-sec gust over land.

Building location:

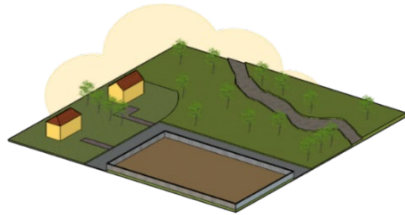

Open country or grasslands

Building geometry:

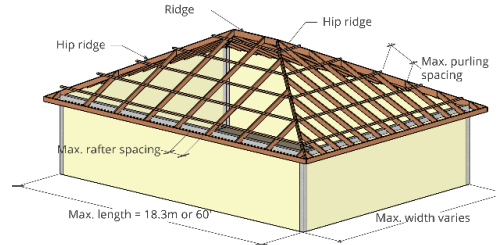

Maximum spacing for rafters based on different typical sizes are indicated in the tables below. Hardwoods and Softwoods are shown in separate tables. Refer to Annex 2 for the list of suitable types of wood considered in this design.

The purlins, for the typical timber hip roof framing, are considered to have a standard size of 50mm x 50mm (2" x 2") at a maximum spacing of 1200mm (4'-0"). Each purlin connection to rafter carries an uplift force of 0.68kN or 153lbs.

The minimum pitch for this roof is 22.6° (5:12).



**Applicable for buildings with a maximum width of 15.3m. (Metric units)**

Softwood: Pines and Cedars				
	Maximum allowable rafter spacing (mm)		Uplift forces at connections (kN)	
Rafter sizes (mm)	Higher strength	Lower strength	Higher strength	Lower strength
150 x 50	350	280*	2.53	2.03
200 x 50	620	500	4.49	3.62
250 x 50	960	770	6.95	5.57

Hardwood: Maples or Oak				
	Maximum allowable rafter spacing (mm)		Uplift forces at connections (kN)	
Rafter sizes (mm)	Higher strength	Lower strength	Higher strength	Lower strength
150 x 50	470	380*	3.4	2.75
200 x 50	830	670	6.01	4.85
250 x 50	1280	1040	9.26	7.53

**Applicable for buildings with a maximum width of 50'. (Imperial units)**

Softwood: Pines and Cedars				
	Maximum allowable rafter spacing (in)		Uplift forces at connections (lbs)	
Rafter sizes (in)	Higher strength	Lower strength	Higher strength	Lower strength
6 x 2	14	11*	569	456
8 x 2	24	20	1009	814
10 x 2	38	30	1562	1252

Hardwood: Maples or Oak				
	Maximum allowable rafter spacing (in)		Uplift forces at connections (lbs)	
Rafter sizes (in)	Higher strength	Lower strength	Higher strength	Lower strength
6 x 2	19	15*	764	618
8 x 2	33	26	1351	1090
10 x 2	50	41	2082	1693

**Applicable for buildings with a maximum width of 18.3m. (Metric units)**

Softwood: Pines and Cedars				
	Maximum allowable rafter spacing (mm)		Uplift forces at connections (kN)	
Rafter sizes (mm)	Higher strength	Lower strength	Higher strength	Lower strength
150 x 50	240	190*	2.08	1.64
200 x 50	430	350*	3.72	3.03
250 x 50	670	540	5.80	4.67

Hardwood: Maples or Oak				
	Maximum allowable rafter spacing (mm)		Uplift forces at connections (kN)	
Rafter sizes (mm)	Higher strength	Lower strength	Higher strength	Lower strength
150 x 50	330	260*	2.86	2.25
200 x 50	580	470	5.02	4.07
250 x 50	890	730	7.7	6.32

**Applicable for buildings with a maximum width of 60'. (Imperial units)**

Softwood: Pines and Cedars				
	Maximum allowable rafter spacing (in)		Uplift forces at connections (lbs)	
Rafter sizes (in)	Higher strength	Lower strength	Higher strength	Lower strength
6 x 2	9	7*	468	369
8 x 2	17	14*	836	681
10 x 2	26	21	1304	1050

Hardwood: Maples or Oak				
	Maximum allowable rafter spacing (in)		Uplift forces at connections (lbs)	
Rafter sizes (in)	Higher strength	Lower strength	Higher strength	Lower strength
6 x 2	13	10*	643	506
8 x 2	23	19	1128	915
10 x 2	35	29	1731	1421

\* Spacing too close and inefficient use of material. Consider using larger size rafters or higher strength wood.

## Buildings in Exposure D

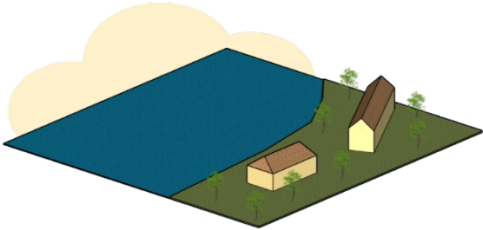
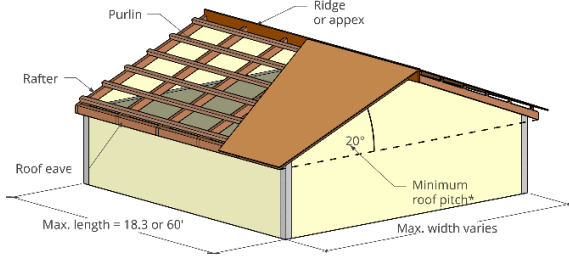
Exposure Category D	Roof type: Gable
Wind speed: 180 mph (80.5 m/s) 3-sec gust over land.	
Building location:  <p style="text-align: center;">A flat unobstructed site facing a large water body.</p>	Building geometry: 

Maximum spacing for rafters based on different typical sizes are indicated in the tables below. Hardwoods and Softwoods are shown in separate tables. Refer to Annex 2 for the list of suitable types of wood considered in this design. The purlins, for the typical timber gable roof framing, are considered to have a standard size of 50mm x 50mm (2" x 2") at a maximum spacing of 915mm (3'-0"). Each purlin connection to rafter carries an uplift force of 0.92kN or 207lbs.

### Applicable for buildings with a maximum width of 15.3m. (Metric units)

Softwood: Pines and Cedars				
	Maximum allowable rafter spacing (mm)		Uplift forces at connections (kN)	
Rafter sizes (mm)	Higher strength	Lower strength	Higher strength	Lower strength
150 x 50	250	200*	2.6	2.01
200 x 50	440	350*	4.58	3.64
250 x 50	680	540	7.07	5.62

Hardwood: Maples or Oak				
	Maximum allowable rafter spacing (mm)		Uplift forces at connections (kN)	
Rafter sizes (mm)	Higher strength	Lower strength	Higher strength	Lower strength
150 x 50	330	270*	3.43	2.81
200 x 50	580	480	6.03	4.99
250 x 50	900	630	9.36	7.7

### Applicable for buildings with a maximum width of 50'. (Imperial units)

Softwood: Pines and Cedars				
	Maximum allowable rafter spacing (in)		Uplift forces at connections (lbs)	
Rafter sizes (in)	Higher strength	Lower strength	Higher strength	Lower strength
6 x 2	10	8*	584	451
8 x 2	17	14*	1030	818
10 x 2	27	21	1539	1263

Hardwood: Maples or Oak				
	Maximum allowable rafter spacing (in)		Uplift forces at connections (lbs)	
Rafter sizes (in)	Higher strength	Lower strength	Higher strength	Lower strength
6 x 2	13	11*	771	632
8 x 2	23	19	1356	1122
10 x 2	35	29	2104	1731

**Applicable for buildings with a maximum width of 18.3m. (Metric units)**

Softwood: Pines and Cedars				
	Maximum allowable rafter spacing (mm)		Uplift forces at connections (kN)	
Rafter sizes (mm)	Higher strength	Lower strength	Higher strength	Lower strength
150 x 50	170	140*	2.12	1.74
200 x 50	310	240*	3.86	2.99
250 x 50	470	380*	5.85	4.73

Hardwood: Maples or Oak				
	Maximum allowable rafter spacing (mm)		Uplift forces at connections (kN)	
Rafter sizes (mm)	Higher strength	Lower strength	Higher strength	Lower strength
150 x 50	230	190*	2.86	2.36
200 x 50	410	330*	5.1	4.11
250 x 50	630	510	7.84	6.35

**Applicable for buildings with a maximum width of 60'. (Imperial units)**

Softwood: Pines and Cedars				
	Maximum allowable rafter spacing (in)		Uplift forces at connections (lbs)	
Rafter sizes (in)	Higher strength	Lower strength	Higher strength	Lower strength
6 x 2	7	6*	477	391
8 x 2	12	9*	868	672
10 x 2	19	15*	1315	1063

Hardwood: Maples or Oak				
	Maximum allowable rafter spacing (in)		Uplift forces at connections (lbs)	
Rafter sizes (in)	Higher strength	Lower strength	Higher strength	Lower strength
6 x 2	9	7*	643	531
8 x 2	16	13*	1146	924
10 x 2	25	20	1762	1427

**Exposure Category D**

**Roof type: Hip**

Wind speed: 180 mph (80.5 m/s) 3-sec gust over land.

Building location:

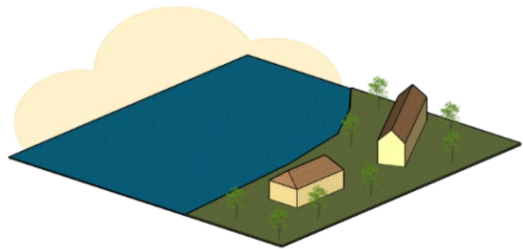

A flat unobstructed site facing a large water body.

Building geometry:

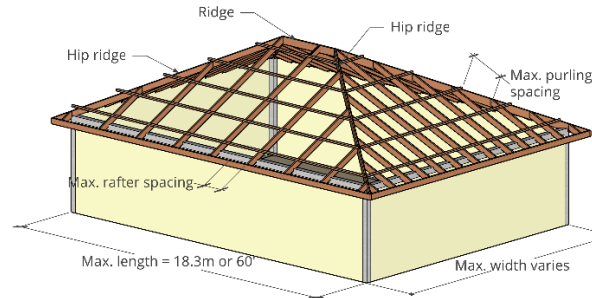

Maximum spacing for rafters based on different typical sizes are indicated in the tables below. Hardwoods and Softwoods are shown in separate tables. Refer to Annex 2 for the list of suitable types of wood considered in this design. The purlins, for the typical timber hip roof framing, are considered to have a standard size of 50mm x 50mm (2" x 2") at a maximum spacing of 915mm (3'-0"). Each purlin connection to rafter carries an uplift force of 0.95kN or 215lbs. The minimum pitch for this roof is 22.6° (5:12).

**Applicable for buildings with a maximum width of 15.3m. (Metric units)**

Softwood: Pines and Cedars				
	Maximum allowable rafter spacing (mm)		Uplift forces at connections (kN)	
Rafter sizes (mm)	Higher strength	Lower strength	Higher strength	Lower strength
150 x 50	290	230*	2.55	2.02
200 x 50	510	410*	4.49	3.61
250 x 50	790	630	6.95	5.54

Hardwood: Maples or Oak				
	Maximum allowable rafter spacing (mm)		Uplift forces at connections (kN)	
Rafter sizes (mm)	Higher strength	Lower strength	Higher strength	Lower strength
150 x 50	380	310*	3.34	2.73
200 x 50	680	550	5.98	4.84
250 x 50	1050	860	9.24	7.56

**Applicable for buildings with a maximum width of 50'. (Imperial units)**

Softwood: Pines and Cedars				
	Maximum allowable rafter spacing (in)		Uplift forces at connections (lbs)	
Rafter sizes (in)	Higher strength	Lower strength	Higher strength	Lower strength
6 x 2	11	9*	573	454
8 x 2	20	16*	1009	812
10 x 2	31	25	1562	1245

Hardwood: Maples or Oak				
	Maximum allowable rafter spacing (in)		Uplift forces at connections (lbs)	
Rafter sizes (in)	Higher strength	Lower strength	Higher strength	Lower strength
6 x 2	15	12*	751	614
8 x 2	27	22	1344	1088
10 x 2	41	34	2077	1699

**Applicable for buildings with a maximum width of 18.3m. (Metric units)**

Softwood: Pines and Cedars				
	Maximum allowable rafter spacing (mm)		Uplift forces at connections (kN)	
Rafter sizes (mm)	Higher strength	Lower strength	Higher strength	Lower strength
150 x 50	200	160*	2.1	1.68
200 x 50	360	280*	3.79	2.95
250 x 50	550	440	5.79	4.63

Hardwood: Maples or Oak				
	Maximum allowable rafter spacing (mm)		Uplift forces at connections (kN)	
Rafter sizes (mm)	Higher strength	Lower strength	Higher strength	Lower strength
150 x 50	270	220*	2.84	2.31
200 x 50	470	390*	4.94	4.1
250 x 50	730	600	7.68	6.31

**Applicable for buildings with a maximum width of 60'. (Imperial units)**

Softwood: Pines and Cedars				
	Maximum allowable rafter spacing (in)		Uplift forces at connections (lbs)	
Rafter sizes (in)	Higher strength	Lower strength	Higher strength	Lower strength
6 x 2	8	6*	472	378
8 x 2	14	11*	852	663
10 x 2	22	17	1302	1041

Hardwood: Maples or Oak				
	Maximum allowable rafter spacing (in)		Uplift forces at connections (lbs)	
Rafter sizes (in)	Higher strength	Lower strength	Higher strength	Lower strength
6 x 2	11	9*	638	519
8 x 2	19	15*	1111	922
10 x 2	29	24	1726	1418

## Chapter 5 Timber Roof Connectors

This section illustrates the typical connectors for timber roof members to resist high winds. The specific type and size of connector depends on the uplift forces that need to be resisted at each connection. It also depends on the proprietary strength of the brand of the hurricane connector available in your specific country.

Note that the uplift forces for the rafters and purlins are included in the design tables in Chapter 4 'Roofs to Resist Category 5 Hurricanes' of this guide. The connector(s) used should have a minimum strength to resist the uplift forces stated in the table.

### Examples of types of connectors

All timber members must have connectors at joints.

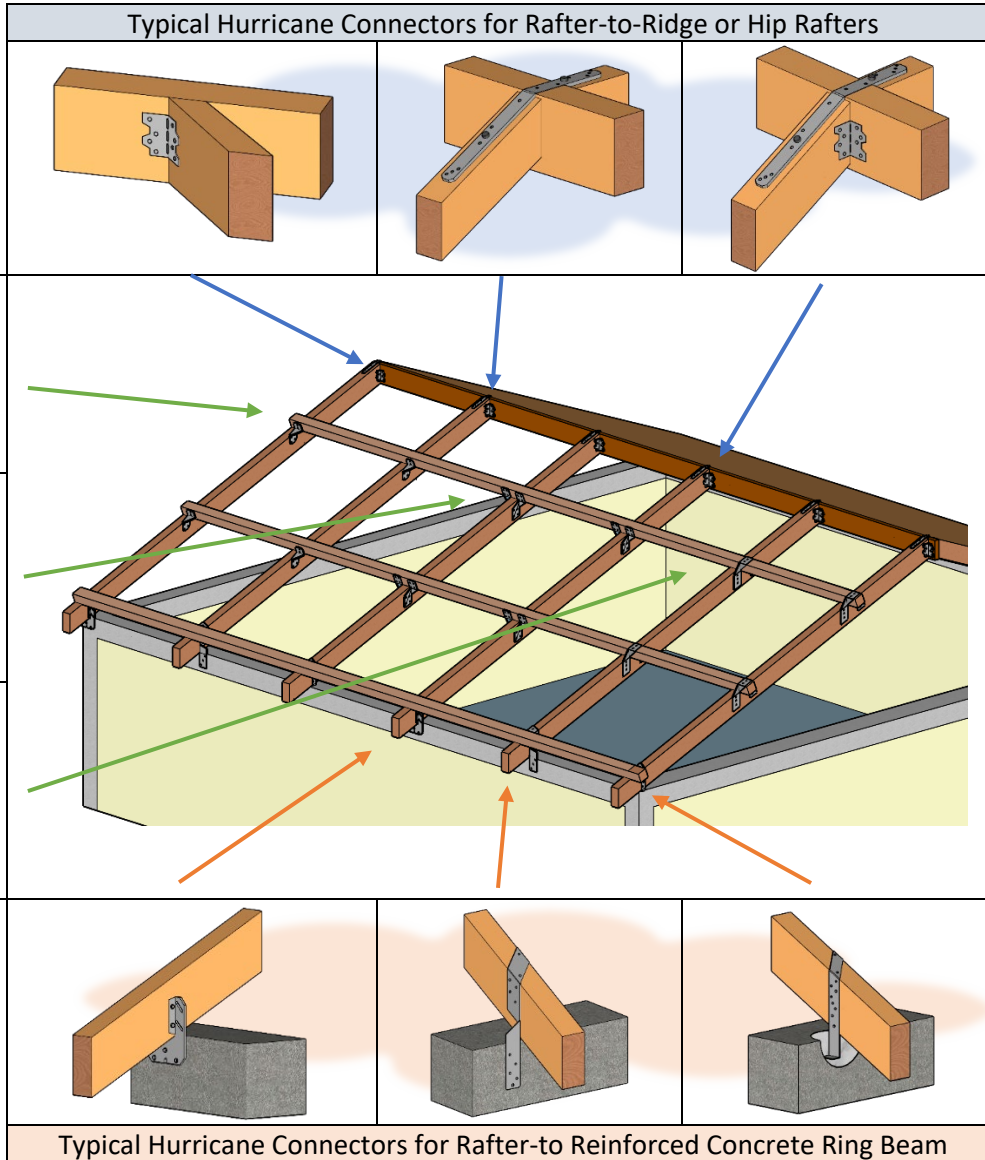

## Prescriptive connectors

PAHO does not advocate for specific suppliers or manufacturers.

In an attempt to make this guide more prescriptive and definitive in the building information provided, the following information has been taken from the Simpson StrongTie® High Wind Guide (online at: <https://embed.widencdn.net/pdf/plus/ssttoolbox/qdm2sqxtml/F-C-HWG20.pdf?u=cjmyin>)(4). This is proprietary information on hurricane straps (connectors) manufactured by Simpson StrongTie®. These connectors are readily available throughout the Americas.

The load tables give the uplift load resistance of each model of connector and the illustrations highlight possible uses for these straps/connectors.

# Using the Tables

**Model No.:**  
This is the Simpson Strong-Tie product name.

**Fasteners:**  
This shows the fastener quantity and type required to achieve the table loads.

**Allowable Design Loads:** The maximum load that a connection is designed to provide. There may be multiple design loads acting in different directions (uplift and lateral, F<sub>1</sub> or F<sub>2</sub>) imposed on a connection.

Model No.	Qty. Req.	No. of Plies (Min.)	Fasteners		Allowable Loads	
			To Girder/Truss	To Wall Framing	DF/SP Uplift (160)	SPF Uplift (160)
H16	1	1	(2) 0.148" x 1 1/2"	(10) 0.148" x 1 1/2"	1,370	1,180
LTT20B <sup>2,3,9</sup>	1	2	(10) 0.148" x 3"	(1) 1/2", 5/8" or 3/4" ATR	1,500	1,290
SS H2.5A	4	2	(20) 0.131" x 1 1/2"	(20) 0.131" x 1 1/2"	1,725 <sup>13</sup>	1,410
SS DTT2Z <sup>2,3,11</sup>	1	1	(8) 1/4" x 1 1/2" SDS	(1) 1/2" ATR	1,825	1,800
SD LGT2	1	2	(16) 0.148" x 3 1/4"	(14) 0.148" x 3 1/4"	2,040	1,755

**Uplift**

**Qty. Req.:** Many tables include quantity of connectors of one, two or even four connectors in some cases.

**No. of Plies (Min.):** Where applicable, for truss/girder connections, multiple plies will be indicated if required.

**Nails:** See p. 52 for other fastener sizes and information.

All installations should be designed only in accordance with the allowable load values set forth in this guide.

Products are listed in order of increasing allowable uplift. Allowable load changes greater than 5% from the previous guide are shown in red.

## Icon Legend

### Extra Corrosion Protection

The teal arrow icon identifies products that are available with additional corrosion protection (ZMAX®, hot-dip galvanized or double-barrier coating). The SS teal arrow icon identifies products also available in stainless steel. Other products may also be available with additional protection; contact Simpson Strong-Tie for options. The end of the product name will indicate what type of extra corrosion protection is provided (Z = ZMAX, HDG = hot-dip galvanized or SS = stainless steel). Stainless products may need to be manufactured upon ordering. See pp. 8–10 for information on corrosion, and visit our website [strongtie.com/info](http://strongtie.com/info) for more technical information on this topic. See p. 52 for more information in stainless steel nail requirements.

### Strong-Drive® SD Connector Screw Compatible

This icon identifies products approved for installation with Simpson Strong-Tie® Strong-Drive® SD Connector screw. See [strongtie.com/sd](http://strongtie.com/sd) for more information.



# Rafter Connectors

Model No.	Qty. Req. <sup>10</sup>	Fasteners (Total)		DF/SP Allowable Loads			SPF Allowable Loads		
		To Truss/Rafter	To Plates	Uplift	Parallel to Plate (F <sub>1</sub> )	Perp. to Plate (F <sub>2</sub> )	Uplift	Parallel to Plate (F <sub>1</sub> )	Perp. to Plate (F <sub>2</sub> )
				(160)	(160)	(160)	(160)	(160)	(160)
H2.5T	1	(5) 0.131" x 1 1/2"	(5) 0.131" x 1 1/2"	420	135	145	420	135	145
H2.5ASS <sup>11</sup>	1	(5) 0.131" x 2 1/2"	(5) 0.131" x 2 1/2"	440	75	70	380	75	70
H1	1	(6) 0.131" x 1 1/2"	(4) 0.131" x 2 1/2"	480	510	190	425	440	165
H2.5T	1	(5) 0.131" x 2 1/2"	(5) 0.131" x 2 1/2"	590	135	145	565	135	145
H2.5A	1	(5) 0.131" x 1 1/2"	(5) 0.131" x 1 1/2"	635 <sup>2</sup>	110	110	540	110	110
HGA10KT	1	(4) 1/4" x 1 1/2" SDS	(4) 1/4" x 3" SDS	650	1,165	940	500	840	675
LTS12 <sup>13</sup>	1	(6) 0.148" x 1 1/2"	(6) 0.148" x 1 1/2"	660 <sup>2</sup>	75 <sup>5</sup>	125 <sup>5</sup>	555	75 <sup>5</sup>	125 <sup>5</sup>
H2.5A	1	(5) 0.131" x 2 1/2"	(5) 0.131" x 2 1/2"	730 <sup>2</sup>	110	110	615	110	110
TSP <sup>9</sup>	1	(9) 0.148" x 1 1/2"	(6) 0.148" x 1 1/2"	755	310	190	650	265	160
H8	1	(5) 0.148" x 1 1/2"	(5) 0.148" x 1 1/2"	780	95	90	710	95	90
H11Z	1	(6) 0.162" x 2 1/2"	(6) 0.162" x 2 1/2"	830	525	760	715	450	655
H10A Sloped	1	(9) 0.148" x 1 1/2"	(9) 0.148" x 1 1/2"	855	590	285	760	505	285
H1	2	(12) 0.131" x 1 1/2"	(8) 0.131" x 2 1/2"	960	1,020	380	850	880	330
H10ASS <sup>11</sup>	1	(9) 0.148" x 1 1/2"	(9) 0.148" x 1 1/2"	970	565	170	835	485	170
MTS12 <sup>13</sup>	1	(7) 0.148" x 1 1/2"	(7) 0.148" x 1 1/2"	990	75 <sup>5</sup>	125 <sup>5</sup>	850	75 <sup>5</sup>	125 <sup>5</sup>
H2.5T	2	(10) 0.131" x 2 1/2"	(10) 0.131" x 2 1/2"	990	270	290	990	270	290
TSP <sup>9</sup>	1	(9) 0.148" x 1 1/2"	(6) 0.148" x 3"	1,015	310	190	875	265	160
H10AR	1	(9) 0.148" x 1 1/2"	(9) 0.148" x 1 1/2"	1,050	490	285	905	420	285
H10A-2	1	(9) 0.148" x 1 1/2"	(9) 0.148" x 1 1/2"	1,080	680	260	930	585	225
H10A	1	(9) 0.148" x 1 1/2"	(9) 0.148" x 1 1/2"	1,105 <sup>2</sup>	565	285	1,015	485	285
H2.5T	2	(10) 0.131" x 2 1/2"	(10) 0.131" x 2 1/2"	1,180	270	290	1,130	270	290
H2.5A	2	(10) 0.131" x 1 1/2"	(10) 0.131" x 1 1/2"	1,270 <sup>2</sup>	220	220	1,080	220	220
H14	1	(12) 0.131" x 1 1/2"	(13) 0.131" x 2 1/2"	1,275	725	285	1,050	480	245
HTS16 <sup>13</sup>	1	(12) 0.148" x 1 1/2"	(12) 0.148" x 1 1/2"	1,310	75 <sup>5</sup>	125 <sup>5</sup>	1,125	75 <sup>5</sup>	125 <sup>5</sup>
LTS12 <sup>13</sup>	2	(12) 0.148" x 1 1/2"	(12) 0.148" x 1 1/2"	1,320 <sup>2</sup>	150 <sup>5</sup>	250 <sup>5</sup>	1,110	150 <sup>5</sup>	250 <sup>5</sup>
H16	1	(2) 0.148" x 1 1/2"	(10) 0.148" x 1 1/2"	1,370	—	—	1,180	—	—
H2.5A	2	(10) 0.131" x 2 1/2"	(10) 0.131" x 2 1/2"	1,460 <sup>2</sup>	220	220	1,230	220	220
MTS12 <sup>13</sup>	2	(14) 0.148" x 1 1/2"	(14) 0.148" x 1 1/2"	1,980	150 <sup>5</sup>	250 <sup>5</sup>	1,700	150 <sup>5</sup>	250 <sup>5</sup>

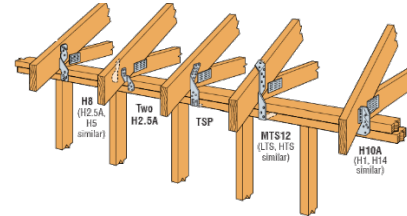



## Truss/Rafter to Masonry/Concrete

Model No.	Qty. Req.	Application	One-Ply SP Rafter/Truss				Two- or Three-Ply SP Rafter/Truss			
			Fasteners to Rafter/Truss (Total) <sup>a</sup>	Uplift (160)	F <sub>1</sub> (160)	F <sub>2</sub> (160)	Fasteners to Rafter/Truss (Total) <sup>a</sup>	Uplift (160)	F <sub>1</sub> (160)	F <sub>2</sub> (160)
HETA12	1	Block/Concrete	(10) 0.148" x 1½"	1,040	390 <sup>7</sup>	1,040	(10) 0.162" x 3½"	1,235	390 <sup>7</sup>	1,040
META12	1	Block/Concrete	(7) 0.148" x 1½"	1,420	340	770	(6) 0.162" x 3½"	1,450	340	770
META16, META18, META20, META24, META40	1	Block/Concrete	(8) 0.148" x 1½"	1,450	340	770	(6) 0.162" x 3½"	1,450	340	770
HETA12	1	Block/Concrete	(7) 0.148" x 1½"	1,455	340	770	(7) 0.162" x 3½"	1,730	340	770
HETA16, HETA20, HETA24, HETA40	1	Block/Concrete	(9) 0.148" x 1½"	1,810	340	770	(8) 0.162" x 3½"	1,810	340	770
HETA16 HETA20	1	Block/Concrete	(14) 0.148" x 1½"	1,810	390 <sup>7</sup>	1,040	(13) 0.162" x 3½"	1,810	390 <sup>7</sup>	1,040
META12, META16, META18, META20, META24, META40	2 <sup>10</sup>	Block	(10) 0.148" x 1½" <sup>10</sup>	1,875	680	770	(14) 0.162" x 3½"	1,795	1,285	1,080
		Concrete						2,435		
HETA12, HETA16, HETA20, HETA24, HETA40	2 <sup>10</sup>	Block	(10) 0.148" x 1½" <sup>10</sup>	1,920	680	770	(12) 0.162" x 3½"	2,365	1,350	1,430
		Concrete						2,560		
HHETA16, HHETA20, HHETA24, HHETA40	2 <sup>10</sup>	Block	(10) 0.148" x 1½" <sup>10</sup>	1,920	680	770	(12) 0.162" x 3½"	2,365	1,350	1,430
		Concrete						3,180		
HHETA16, HHETA20, HHETA24, HHETA40	1	Block/Concrete	(10) 0.148" x 1½"	2,120	340 <sup>8</sup>	770	(9) 0.162" x 3½"	2,120	340 <sup>8</sup>	770
DETAL20	1	Block/Concrete	(18) 0.148" x 1½" <sup>10</sup>	2,480	2,000	1,370	—	—	—	—

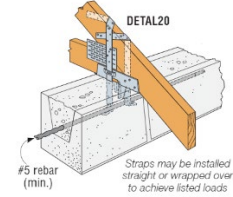
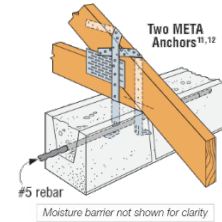
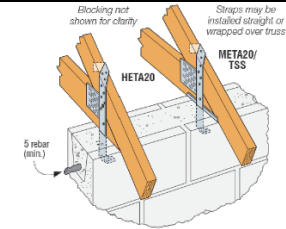

## Hip Rafter to Wall Connector

Model No.	Member Size	Fasteners		DF/SP Allowable Loads (160)		SPF Allowable Loads (160)	
		To Truss/Rafter	To Wall	Uplift	F <sub>1</sub>	Uplift	F <sub>1</sub>
TJC37 (1-85°)	2x4 min.	(6) 0.131" x 1½"	(6) 0.131" x 1½"	375 <sup>7</sup>	—	325 <sup>7</sup>	—
TJC57 (1-85°)	2x6 min.	(12) 0.131" x 1½"	(12) 0.131" x 1½"	750 <sup>7</sup>	—	645 <sup>7</sup>	—
HCP2 <sup>1</sup>	2x	(6) 0.148" x 1½"	(6) 0.148" x 1½"	590	255	510	220
HCP1.81 <sup>1</sup>	1¾	(6) 0.148" x 1½"	(6) 0.148" x 1½"	590	255	510	220
MTSM16	2x	(7) 0.148" x 1½"	(4) ¼" x 2¼" Titen Turbo <sup>MS</sup>	830	—	715	—

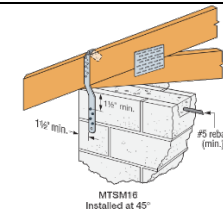

## Rafter Connectors

	Model No.	Qty. Req. <sup>10</sup>	Fasteners (Total)		DF/SP Allowable Loads			SPF Allowable Loads		
			To Truss/Rafter	To Plates	Uplift (160)	Parallel to Plate (F <sub>1</sub> ) (160)	Perp. to Plate (F <sub>2</sub> ) (160)	Uplift (160)	Parallel to Plate (F <sub>1</sub> ) (160)	Perp. to Plate (F <sub>2</sub> ) (160)
	H2.5T	1	(5) 0.131" x 1 1/2"	(5) 0.131" x 1 1/2"	420	135	145	420	135	145
SS	H2.5ASS <sup>11</sup>	1	(5) 0.131" x 2 1/2"	(5) 0.131" x 2 1/2"	440	75	70	380	75	70
	H1	1	(6) 0.131" x 1 1/2"	(4) 0.131" x 2 1/2"	480	510	190	425	440	165
	H2.5T	1	(5) 0.131" x 2 1/2"	(5) 0.131" x 2 1/2"	590	135	145	565	135	145
	H2.5A	1	(5) 0.131" x 1 1/2"	(5) 0.131" x 1 1/2"	635 <sup>2</sup>	110	110	540	110	110
	HGA10KT	1	(4) 1/4" x 1 1/2" SDS	(4) 1/4" x 3" SDS	650	1,165	940	500	840	675
	LTS12 <sup>13</sup>	1	(6) 0.148" x 1 1/2"	(6) 0.148" x 1 1/2"	660 <sup>2</sup>	75 <sup>5</sup>	125 <sup>5</sup>	555	75 <sup>5</sup>	125 <sup>5</sup>
	H2.5A	1	(5) 0.131" x 2 1/2"	(5) 0.131" x 2 1/2"	730 <sup>2</sup>	110	110	615	110	110
	TSP <sup>9</sup>	1	(9) 0.148" x 1 1/2"	(6) 0.148" x 1 1/2"	755	310	190	650	265	160
SS	H8	1	(5) 0.148" x 1 1/2"	(5) 0.148" x 1 1/2"	780	95	90	710	95	90
	SDWC15600 <sup>12</sup>	1	—	—	805 <sup>2</sup>	380 <sup>2</sup>	225	505	265	190
	H11Z	1	(6) 0.162" x 2 1/2"	(6) 0.162" x 2 1/2"	830	525	760	715	450	655
	H10A Sloped	1	(9) 0.148" x 1 1/2"	(9) 0.148" x 1 1/2"	855	590	285	760	505	285
	H1	2	(12) 0.131" x 1 1/2"	(8) 0.131" x 2 1/2"	960	1,020	380	850	880	330
	H10ASS <sup>11</sup>	1	(9) 0.148" x 1 1/2"	(9) 0.148" x 1 1/2"	970	565	170	835	485	170
SS	MTS12 <sup>13</sup>	1	(7) 0.148" x 1 1/2"	(7) 0.148" x 1 1/2"	990	75 <sup>5</sup>	125 <sup>5</sup>	850	75 <sup>5</sup>	125 <sup>5</sup>
	H2.5T	2	(10) 0.131" x 2 1/2"	(10) 0.131" x 2 1/2"	990	270	290	990	270	290
	TSP <sup>9</sup>	1	(9) 0.148" x 1 1/2"	(6) 0.148" x 3"	1,015	310	190	875	265	160
	H10AR	1	(9) 0.148" x 1 1/2"	(9) 0.148" x 1 1/2"	1,050	490	285	905	420	285
	H10A-2	1	(9) 0.148" x 1 1/2"	(9) 0.148" x 1 1/2"	1,080	680	260	930	585	225
	H10A	1	(9) 0.148" x 1 1/2"	(9) 0.148" x 1 1/2"	1,105 <sup>2</sup>	565	285	1,015	485	285
	H2.5T	2	(10) 0.131" x 2 1/2"	(10) 0.131" x 2 1/2"	1,180	270	290	1,130	270	290
	SDWC15600 <sup>12</sup>	2	—	—	1,200	685	995	1,045	495	670
	H2.5A	2	(10) 0.131" x 1 1/2"	(10) 0.131" x 1 1/2"	1,270 <sup>2</sup>	220	220	1,080	220	220
	H14	1	(12) 0.131" x 1 1/2"	(13) 0.131" x 2 1/2"	1,275	725	285	1,050	480	245
	HTS16 <sup>13</sup>	1	(12) 0.148" x 1 1/2"	(12) 0.148" x 1 1/2"	1,310	75 <sup>5</sup>	125 <sup>5</sup>	1,125	75 <sup>5</sup>	125 <sup>5</sup>
SS	LTS12 <sup>13</sup>	2	(12) 0.148" x 1 1/2"	(12) 0.148" x 1 1/2"	1,320 <sup>2</sup>	150 <sup>5</sup>	250 <sup>5</sup>	1,110	150 <sup>5</sup>	250 <sup>5</sup>
	H16	1	(2) 0.148" x 1 1/2"	(10) 0.148" x 1 1/2"	1,370	—	—	1,180	—	—
	H2.5A	2	(10) 0.131" x 2 1/2"	(10) 0.131" x 2 1/2"	1,460 <sup>2</sup>	220	220	1,230	220	220
SS	MTS12 <sup>13</sup>	2	(14) 0.148" x 1 1/2"	(14) 0.148" x 1 1/2"	1,980	150 <sup>5</sup>	250 <sup>5</sup>	1,700	150 <sup>5</sup>	250 <sup>5</sup>

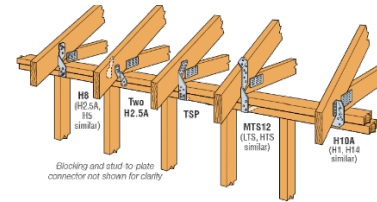

## Chapter 6 Roof Sheeting

Typically, corrugated galvanised metal roof sheets are used as the lightweight, affordable, and easy-to-install metal roof sheeting over most buildings. Galvanised metal sheets are generally defined by the gauge: 22ga., 24ga. The higher the gauge number, the thinner the sheet thickness. Galvanised metal consists of a thin layer of zinc anticorrosive coating to protect the inner mild steel metal sheet.

There are other types of durable anticorrosive metal sheets, such as Galvalume. This is where the base metal is protected with a layer of Aluminum (Al), Zinc (Zn) and Silicon (Si). It is similar in appearance to galvanized sheets and has similar durability benefits; however, Galvalume may be more durable in coastal environments.

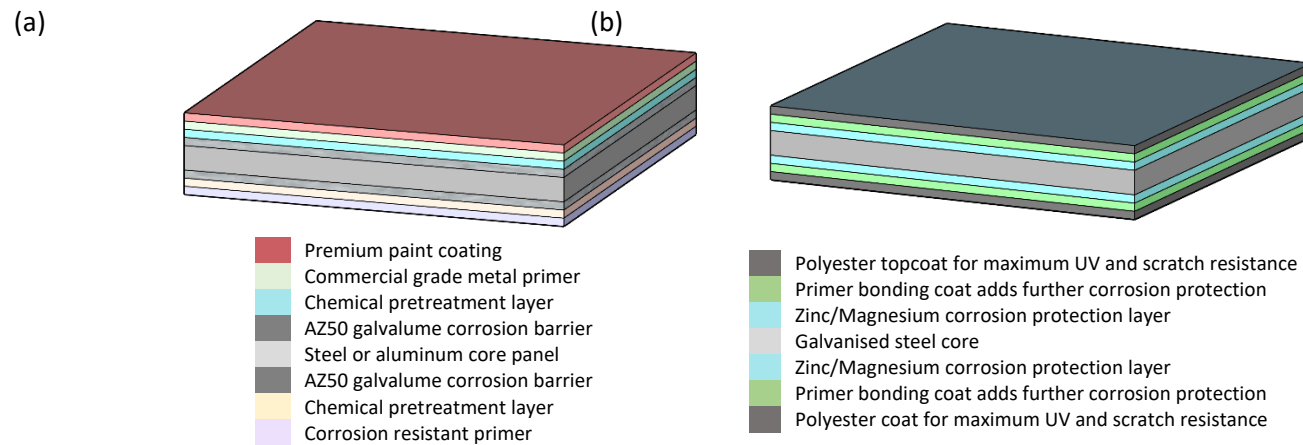

Figure 7 (a) Typical Galvalume layers, (b) Typical Galvanised layers

## Roof sheets

Metal roof sheets come in many different proprietary profile shapes, such as those illustrated below:

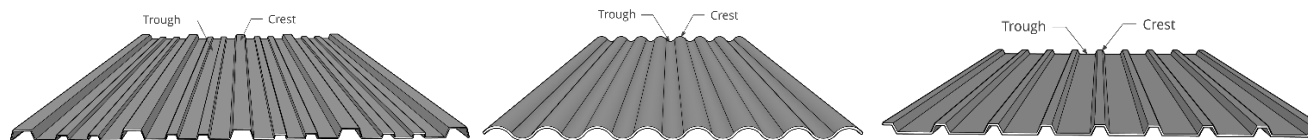

Figure 8 Examples of different roof sheet profile shapes

Different manufacturers use different layer composition, thicknesses, and profiles to achieve the strength and durability of the metal sheeting. There is no standard industry thickness related to gauge, that is, 24-gauge may refer to 0.45mm thick from one manufacturer and 0.5mm thick from a different manufacturer.

It is important to check that the metal sheeting used on the building is suitable for the environment in which the building is located. Marine and coastal environments may require thicker anti-corrosive protection than buildings located in inland urban or country areas.

### Roofing screws

There are specific sections of gable or hip roofs that attract higher wind pressures (refer to light orange perimeter strips around each face of the roof in image 9 below). The roof sheets should be connected using galvanised or stainless-steel metal screws at appropriate maximum spacings to ensure that the roof sheet does not tear or rip off in high winds. The high wind pressure zones may require that roof screws in these areas are spaced more closely together. Usually, the roof sheet manufacturer specifies the maximum allowable spacing of the screws to ensure the design resistance is achieved.

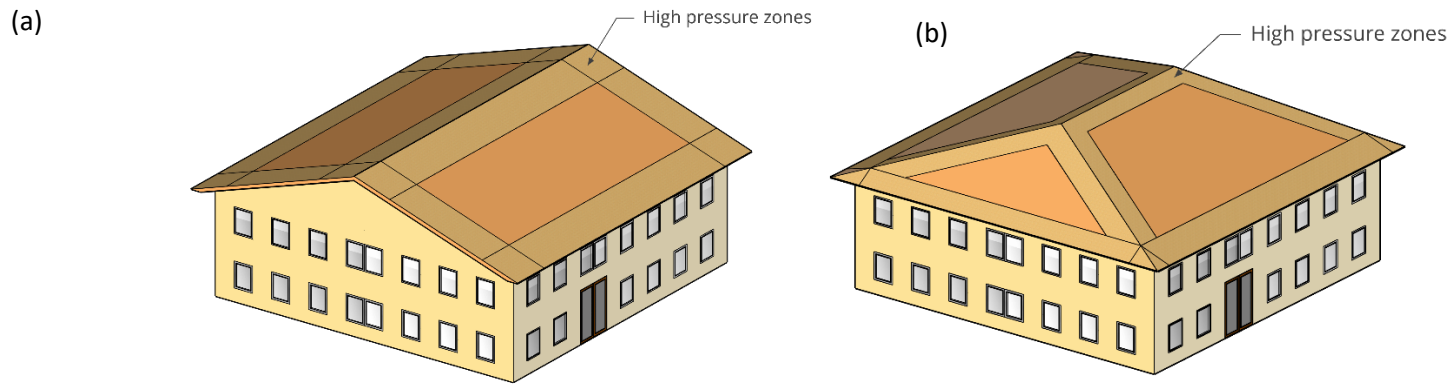
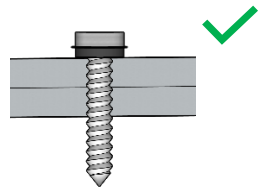

Figure 9 (a) High pressure zones in gable roofs, (b) High pressure zones in hip roofs

Leak prevention between the roofing screw and roof sheet connection can be achieved by the following:

1. Using roofing screws that have a compressible rubber gasket under the washer to prevent water ingress under the washer; installing the screws properly.

2.



Correctly driven, straight, good penetration, no under driven or over driven, firmly against the surface.

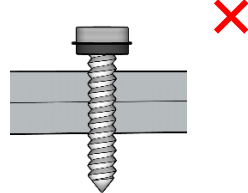

Underdriven, not proper penetration

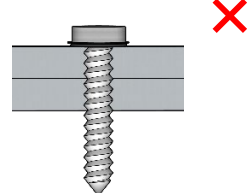

Overdrive, gasket overly compressed, bulges at sides

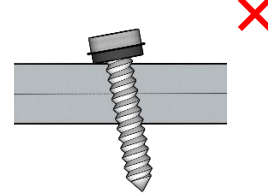

Crooked penetration, could cause leakages

Figure 10 Roofing screw positioning

3. Connect the screws through the crest of the corrugated roof sheets. This location will ensure the screw penetration is exposed to less water than the valley of the roof sheet and that the screw head has enough space for the connection. Manufacturers of different roof sheet profiles would specify the correct location and spacing of the roof screws to satisfy wind pressures. Also ensure that roof sheets have adequate lap between sheets, as per the manufacturer's specifications.

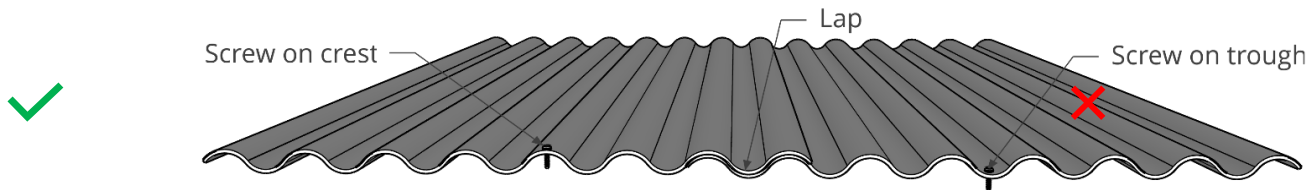
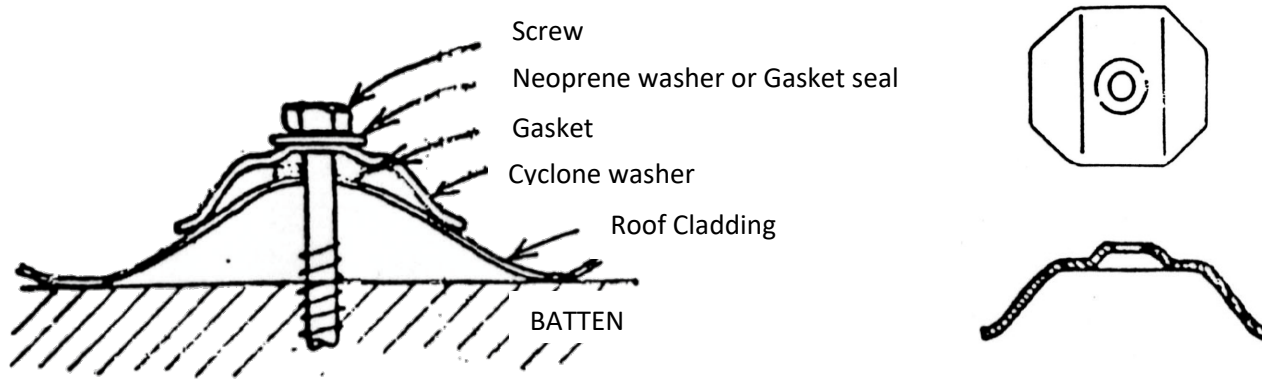
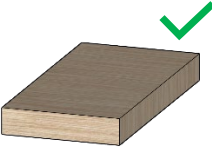



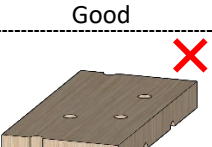
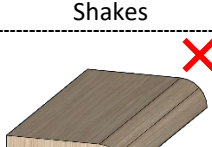
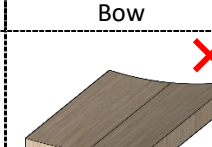
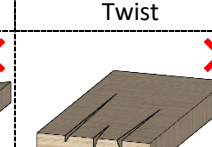
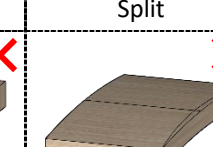

Figure 11 Screw connection on roof sheet

4. Use cyclone washers. An example is shown in the figure below.



## Chapter 7 Quality Control Checklist

Task					Status
Check the quality of the timber. Check that the timber has no defects such as knots, splits, rotting or water-damaged parts.					<input type="checkbox"/>
 Good	 Shakes	 Bow	 Twist	 Split	
 Knotholes	 Wane	 Cup	 Checks	 Crook	
Ensure the timber members are treated to resist insect and termite attacks and weathering. This should be verified before purchase.					<input type="checkbox"/>
Check that the correct sizes of the rafters and purlins are used at the correct maximum spacing. (Refer to the tables in chapter 4).					<input type="checkbox"/>

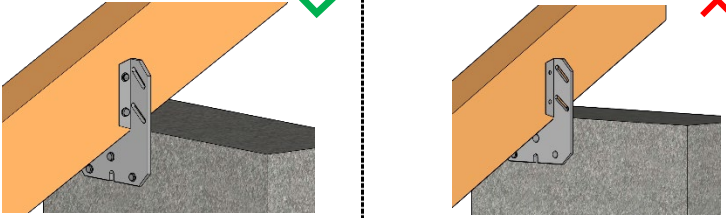
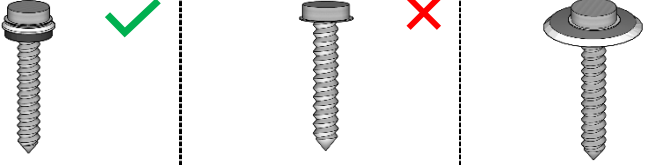
<p>Check that the minimum roof pitch is correct. (at least 20°).</p>	<input type="checkbox"/>
<p>Check that all joints, intersection between timber members and timber to wall or beams, have the correct hurricane connector with the correct number of nails or screws.</p> <div data-bbox="359 289 1213 570" style="border: 1px dashed black; padding: 5px;">  <p style="display: flex; justify-content: space-around;"> <span>Connector with <b>correct</b> screws</span> <span>Connector with <b>missing</b> screws/ nails</span> </p> </div>	<input type="checkbox"/>
<p>Check that the roof sheeting is corrosion-resistant and meets the correct minimum thickness. Also check the allowable wind pressure and roof screw maximum spacing. This should be verified before purchase.</p>	<input type="checkbox"/>
<p>Check that the correct size, spacing and type of roof sheeting screws are used with washers.</p> <div data-bbox="359 748 1213 1003" style="border: 1px dashed black; padding: 5px;">  <p style="display: flex; justify-content: space-around;"> <span>Screw with <b>correct</b> size washer and rubber gasket</span> <span>Screw <b>without</b> washer and rubber gasket</span> <span>Screw with <b>wrong</b> oversized washer</span> </p> </div>	<input type="checkbox"/>

## Bibliography

1. AON. Weather, Climate & Catastrophe Insight. 2020;78. Available from: <http://catastropheinsight.aon.com>
2. Choices made now are critical for the future of our ocean and cryosphere — IPCC [Internet]. [cited 2021 Jan 27]. Available from: <https://www.ipcc.ch/2019/09/25/srocc-press-release/>
3. Chapter 2 Building Performance - Further information on building geometry and building performance can be found on Whole Building Design - Seismic Design Principles. Available from: <https://www.wbdg.org/resources/seismic-design-principles>
4. Chapter 3 Building Components Masonry Walls - Further information and minimum building standards can be found in the 'Building Guidelines based on the OECS 2015 Building Codes'. Available from: <https://www.oecs.org/>
5. Engineers AS of C. Minimum Design Loads and Associated Criteria for Buildings and Other Structures [Internet]. American Society of Civil Engineers; Available from: <https://ascelibrary.org/doi/book/10.1061/9780784414248>
6. Chapter 5 Prescriptive connectors available from Strong-Tie S. High Wind Guide [Internet]. Available from: <https://embed.widencdn.net/pdf/plus/ssttoolbox/qdm2sqxtml/F-C-HWG20.pdf?u=cjmyin>
7. Chapter 6 Roofing Screws - Further information can be found on Metal Roof Repair- 5 Common Causes of Metal Roof Leaks. Available from <https://www.exteriorproinc.com/blog/metal-roof-repair-5-common-causes-of-metal-roof-leaks>
8. Chapter 6 Cyclone washers - Further information can be found on 'Fastener Requirements For High Wind & Cyclonic Areas'. Available from: <https://www.buildex.com.au/technical-advice/high-wind-cyclonic-areas/>
9. Chapter 7 Quality of the timber - Further information can be found on 'Timber Defects'. Available from: [http://wiki.dtonline.org/index.php/Timber\\_Defects](http://wiki.dtonline.org/index.php/Timber_Defects)
10. Annex 1 Wind Speeds - Further information can be found on PAHO Caribbean Basin Wind Hazard Maps Aid in Siting of Hospitals. Available from: <https://www.paho.org/en/health-emergencies/smart-hospitals/caribbean-basin-wind-hazard-maps-aid-siting-hospitals>
11. Annex 2 – Further information can be found on 'Mechanical properties of wood' accessed from <https://www.fs.usda.gov/treesearch/pubs/7149>



## Annex 1 – Wind Speeds

### **Relationship between Wind Speeds in Design Codes and Saffir–Simpson scale Hurricane Wind Scale**

The hurricane reports from the National Hurricane Center include the Saffir-Simpson Hurricane Categories 1 to 5. This scale is relied on by local emergency management agencies in order to warn the populations of the need to prepare for upcoming severe weather systems. The Saffir-Simpson Hurricane Scale has wide acceptance and popularity. Its five Categories are based on wind speed intensity and barometric pressure at the centre of the storm. The quoted wind speeds determining the various Categories are sustained wind speeds with a 1-minute averaging time at 33 ft over open water. It is understood that the wind speeds categorising the hurricanes are the most intense in the system – typically in the north-east eye wall. Those speeds are not necessarily the ones impacting on any particular island or part of an island.

It is important to note that the wind speeds reported by the National Hurricane Centre are not the same as those determined by researchers specifically for use in the design of structures.

The American Society of Civil Engineers ASCE 7 standard commonly used by engineers for wind-resistant design purposes in the USA and the Caribbean uses a 3-second gust speed at 33 ft above ground in open terrain with scattered obstructions having heights generally less than 30 feet – commonly associated with flat open country and grasslands. This is known as Exposure C. The wind speed thus defined is the Basic Wind Speed for use in structural design.

This section lists basic wind speeds for different return periods across several countries in the Americas. The basic wind speed is used to develop the design wind speeds for building design in the respective countries. The Saffir-Simpson Hurricane Scale wind speeds are also included as a comparison between the basic wind speeds versus Category 5 Hurricane wind speeds.

**Table 1.1. Approximate Relationship between Wind Speeds in ASCE 7 and Saffir-Simpson scale Hurricane Wind Scale**

Hurricane Category	Sustained Wind Speed over Water		Gust Wind Speed over Water		Gust Wind Speed over Land	
	<i>mph</i>	<i>m/s</i>	<i>mph</i>	<i>m/s</i>	<i>mph</i>	<i>m/s</i>
1	74-95	33-42	90-116	40-51	81-105	36-47
2	96-110	43-49	117-134	52-59	106-121	48-54
3	111-129	50-57	135-157	60-70	122-142	55-63
4	130-156	58-69	158-190	71-84	143-172	64-76
5	>157	>70	>191	>85	>173	>77

**Note:** Country wind speeds in red text exceed the minimum wind speed for Category 5 Hurricanes.

**Table 1.2. Wind speeds - The Caribbean**

**Note:** 2019 PAHO wind hazard maps publication(5), same as the OECS Building Code wind speeds (updated in September 2016). When using ASCE 7-10 the following values shall be adopted for the Basic Wind Speed V for Category II Buildings.

Location	700-year [mph]	1700-year [mph]
Trinidad (S)	87	110
Trinidad (N)	128	147
Isla Margarita	133	152
Grenada	154	168
Bonaire	149	156
Curacao	149	165
Aruba	146	162
Barbados	152	169

Saint Vincent	155	171
Saint Lucia	155	172
Martinique	159	171
Dominica	159	172
Guadeloupe	157	168
Montserrat	161	172
St. Kitts and Nevis	163	170
Antigua and Barbuda	160	168
Saint Martin/Sint Maarten	167	175
Anguilla	165	176
US Virgin Islands	167	176
British Virgin Islands	169	180
Grand Cayman	187	198
Little Cayman/Cayman Brac	178	197
Hispaniola	110-160	120-170
Jamaica	140-160	150-170

**Note:** The above values are 700-year return period for Category II Buildings and 1700-year return period for Category III and IV Buildings. These are “failure” wind speeds therefore a Load Factor of 1.0 does not need to be applied.

**Table 1.3. Wind speeds - Latin America**

Location	50-year [mph]	200-year [mph]	700-year [mph]	1700-year [mph]
Cuba			120-170	140-190
Dominic Republic			120-175	125-185
Puerto Rico			150-170	160-180
Mexico	56-144	62-177		
Guatemala			70-140	
Honduras			70-170	
El Salvador <sup>§</sup>				
Nicaragua	67-125	81-157	70-170	
Costa Rica	62-87			
Panama	72-87			

Brazil	67-112		
Colombia		70-120	
Colombia Archipelago:			
Providencia and Santa Catalina		140	155
San Andrés		125	145
Venezuela (excluding Margarita)		70-130	

<sup>§</sup> El Salvador building code states a basic wind pressure of 30 kgf/m<sup>2</sup> or 0.3kPa. This is derived from a wind speed of 15.4 m/s or 34.6 mph, however neither the averaging period nor the return period are identified.

## Annex 2 – List of Hardwoods and Softwoods

Types of Softwoods and Hardwoods that are suitable for use in the designs illustrated in this guide are listed here.

Softwood		
Material	Higher strength	Lower strength
<b>Cedar</b>	Eastern red cedar	Atlantic white
	Incense	Northern white
	Port-Orford	Western redcedar
	Yellow	
<b>Pine</b>	Jack	Eastern white
	Loblolly	Lodgepole
	Longleaf	Ponderosa
	Pitch	Red
	Pond	Spruce
	Sand	Sugar
	Shortleaf	Western white
	Slash	
	Virginia	

**Notes:**  
Design stresses considered for the higher strength softwood are:

- Bending stress parallel to grain,  $S_p = 21.2 \text{ N/mm}^2$
- Shear stress parallel to grain,  $S_v = 5.9 \text{ N/mm}^2$

Design stresses considered for the lower strength softwood are:

- Bending stress parallel to grain,  $S_p = 16.5 \text{ N/mm}^2$
- Shear stress parallel to grain,  $S_v = 4.8 \text{ N/mm}^2$

Hardwood		
Material	Higher strength	Lower strength
<b>Cherry</b>	Black	
<b>Maple</b>	Sugar	Bigleaf
		Black
		Red
		Silver
<b>Oak, red</b>	Black	Laurel
	Cherrybark	Northern red
	Pin	Southern red
	Scarlet	Willow
	Water	
<b>Oak, white</b>	Chestnut	Bur
	Live	Overcup
	Post	
	Swamp chestnut	
	Swamp white	
	White	
<b>Walnut</b>	Black	

**Notes:**  
Design stresses considered for the higher strength hardwood are:

- Bending stress parallel to grain,  $S_p = 27.3 \text{ N/mm}^2$
- Shear stress parallel to grain,  $S_v = 9.3 \text{ N/mm}^2$

Design stresses considered for the lower strength hardwood are:

- Bending stress parallel to grain,  $S_p = 22.3 \text{ N/mm}^2$
- Shear stress parallel to grain,  $S_v = 8.1 \text{ N/mm}^2$

## Annex 3 – Sample Calculation

The sample calculations in this annex are for reference by civil/structural engineers who may be using this guide.

Project: <b>Hurricane Resistant Buildings</b>					Date: <b>12-Jul-21</b>
Engineer: <b>Shalini Jagnarine-Azan</b>					Page: <b>1 of 5</b>
Description: <b>Gable Roof_180mph_Exposure B</b>					
Design reference code: ASCE 7-16					
Input all items in <b>red</b> .					
Wind Loads based on Category 5 Hurricanes: 3-sec gust wind speeds over land: >173mph (77m/s)					
<b>Item description:</b>	Value	Unit	Reference	Unit	Notes
Basic wind speed, V	80.5	m/s =	<b>180</b>	mph	BASIC WIND SPEED, V: Three-second gust speed at 33 ft (10 m) above the ground in Exposure C (see Section 26.7.3) as determined in accordance with Section 26.5.1.
<b>Building description:</b>					
Enclosed			26.2		BUILDING, ENCLOSED: A building that has the total area of openings in each wall, that receives positive external pressure, less than or equal to 4 sq ft (0.37 m <sup>2</sup> ) or 1% of the area of that wall, whichever is smaller. This condition is expressed for each wall by the following equation: $A_o < 0.01A_g$ ; or $4 \text{ sq ft} \leq 0.37 \text{ m}^2$ ; whichever is smaller; where $A_o$ = total area of openings in a wall that receives positive external pressure, in ft <sup>2</sup> (m <sup>2</sup> ); and $A_g$ = the gross area of that wall in which $A_o$ is identified, in ft <sup>2</sup> (m <sup>2</sup> ).
Low-rise			26.2		BUILDING, LOW-RISE: Enclosed or partially enclosed building that complies with the following conditions: 1. Mean roof height h less than or equal to 60 ft (18 m). 2. Mean roof height h does not exceed least horizontal dimension.
Building category	<b>III</b>				Table 1.5-1, ASCE 7-16 in hurricane prone region
Importance factor	<b>1.00</b>		Table 6.1		Buildings and other structures, the failure of which could pose a substantial risk to human life
<b>Site Location:</b>					
Surface roughness	<b>B</b>		26.7.2		Surface Roughness B: Urban and suburban areas, wooded areas, or other terrain with numerous, closely spaced obstructions that have the size of single-family dwellings or larger
Exposure	<b>B</b>		26.7.3		Exposure B: For buildings or other structures with a mean roof height less than or equal to 30 ft (9.1 m), Exposure B shall apply where the ground surface roughness, as defined by Surface Roughness B
Wind Directionality factor, $K_d$	<b>0.85</b>		Table 26.6-1		main wind force-resisting system
<b>Topographic Effects:</b>					
Topographical factor, $K_{zt}$	<b>1</b>		26.8		$K_{zt} = (1+K_1K_2K_3)^2$ Taken for ease of calculation in this template
Gust-Effect Factor. The gust-effect factor for a rigid					

Project:	<b>Hurricane Resistant Buildings</b>				Date:	<b>12-Jul-21</b>
Engineer:	<b>Shalini Jagnarine-Azan</b>				Page:	<b>2 of 5</b>
Description:	<b>Gable Roof_180mph_Exposure B</b>					
<b>Building Geometry:</b>	Value	Unit	Reference	Unit	Notes	
Structure height, h	<b>10</b>	m =	33	ft	Assume max. 3-storeys	
Roof angle	<b>20</b>	degrees			Use this as the minimum recommended pitch for all roofs, 4' 3/8": 1' (4.38:12)	
Building length, L	<b>24.5</b>	m =	80.4	ft	Use maximum building width & length as 80ft, 24.5m	
h/L =	0.41					
Wind Velocity pressure, $q_z = 0.613 K_z K_{zt} K_d K_e V^2$ (N/m <sup>2</sup> )						
<b>hence, <math>q_z = q_h = 2.43</math> kN/m<sup>2</sup></b>						
<b>Important Note:</b>						
26.12.3 Protection of Glazed Openings. Glazed openings in Risk Category II, III, or IV buildings located in hurricane-prone regions shall be protected as specified in this section.						
26.12.3.1 Wind-Borne Debris Regions. Glazed openings shall be protected in the following:						
1. Within 1 mi (1.6 km) of the coastal mean high water line where the basic wind speed is equal to or greater than 130 mi/h (58 m/s), or						
2. In areas where the basic wind speed is equal to or greater than 140 mi/h (63 m/s).						
<b>Internal pressure Coefficient</b>						
			Table 26.13-1		for enclosed building	
	0.18					
coefficient, GC <sub>pi</sub>	-0.18					
<b>WIND LOADS ON BUILDINGS: MAIN WIND FORCE RESISTING SYSTEM (ENVELOPE PROCEDURE)</b>						
Ref. Chapter 28						Reference
Wind pressure, $p = q_h \cdot [GC_{pf} - GC_{pi}]$		N/m <sup>2</sup>				28.3-1
<b>Building Geometry Assumptions:</b>						
Length, L =	24.5	m =	80.4	ft		
Width, w =	9.8	m =	32.2	ft	Assume width is half length	
Width of edge zones E, $a = 0.4h =$			4	m or $a = 10\% (w) =$	0.98 m	
But a cannot be less than, 4% of w =			0.392	m or $a =$	0.98 m	
<b>=&gt; width of edge pressure zones, 2E &amp; 3E, a =</b>			<b>0.98</b>	<b>m</b>		
Width of edge higher wind pressure zones, for closer spacing roof sheet connectors, a:						
Building width (m)	a (m)					
24.5	2.45					
19.6	1.96					
18.4	1.84					



Project:	<b>Hurricane Resistant Buildings</b>				Date:	<b>12-Jul-21</b>		
Engineer:	<b>Shalini Jagnarine-Azan</b>				Page:	<b>3</b>	<b>of</b>	<b>5</b>
Description:	<b>Gable Roof_180mph_Exposure B</b>							
External pressure coefficients	Roof zones, for 20deg angle							
	2	2E	3	3E				
coefficient, GCpf	-0.69	-1.07	-0.48	-0.69	Load Case A - wind direction predominantly on long side of building			
coefficient, GCpf	-0.69	-1.07	-0.37	-0.53	Load Case B - wind direction predominantly on short side of building			
GCpf - GCpi	-0.87	-1.25	-0.66	-0.87	Load Case A			
	-0.87	-1.25	-0.55	-0.71	Load Case B			
wind pressure, p (kN/m2)	-2.11	-3.04	-1.60	-2.11	Load Case A			
	-2.11	-3.04	-1.34	-1.72	Load Case B			
<b>Use maximum pressure in main roof area, zones 2 and 3, p =</b>					<b>-2.11</b>	<b>kN/m2 =</b>	<b>-44.1</b>	<b>psf</b>
<b>Use maximum pressure in edge roof area, zones 2E and 3E, pe =</b>					<b>-3.04</b>	<b>kN/m2 =</b>	<b>-63.4</b>	<b>psf</b>
<b>Loading:</b>								
Dead load for timber roof, D:								
Light frame wood roof with board ceiling, waterproofing and insulation (3psf) & metal sheeting =								
			14	psf =	0.67	kPa		
Roof live load, Lr =								
		20	psf =	0.96	kPa	Ref. IBC2018 Tbl 1607.1		
Force due to wind pressure, W:								
Consider high-pressure edge areas as critical design load, W =								
			-63.4	psf =	-3.04	kPa		
<b>Basic Load Combinations:</b>								
		psf	kPa (kN/m2)					
Load case 1:	D + Lr	34.0	1.63					
Load case 2:	D + 0.6W	-24.0	-1.15					
Load case 3:	D + 0.75Lr + 0.45W	0.5	0.02					
Load case 4:	0.6D + 0.6W	-29.6	-1.42					
Most onerous load case for design check of timber members, F								
			-29.6	psf =	-1.42	kPa		
<b>Timber rafter check:</b>								
Material:								
Caribbean pitch pine = GS C18 strength class or SS C27								
Material properties:								
Bending parallel to grain, Sp =		27.3	N/mm2					
Shear parallel to grain, Sv =		9.25	N/mm2					
Gable Roof Geometric properties based on max. roof dimensions and min. pitch:								
Recall max. building length (L) and width (W) =								
		24.5	m =	80.4	ft			

Project:	<b>Hurricane Resistant Buildings</b>				Date:	<b>12-Jul-21</b>	
Engineer:	<b>Shalini Jagnarine-Azan</b>				Page:	<b>4</b>	<b>of 5</b>
Description:	<b>Gable Roof_180mph_Exposure B</b>						
Check timber rafter size:							
rafter depth, H =	<b>150</b>	mm x	width, B =	<b>50</b>	mm		
Dressed timber section, h =	144	mm x	width, b =	44	mm		
Material properties of timber:							
Bending parallel to grain, Sp =	27.3	N/mm <sup>2</sup>					
Shear parallel to grain, Sv =	9.3	N/mm <sup>2</sup>					
wet exposure coefficient, k2 =	0.9						
duration load factor, k3 =	1.75	for D + L + W in 3-sec gusts					
depth modification factor, k7 =	1.08	k7 = (300/h) <sup>0.11</sup> for beam depths <300mm					
Section modulus, Z = (1/6) x BH <sup>2</sup> =		187500	mm <sup>3</sup>				
Section modulus based on dressed timber size, S <sub>y</sub>		152064	mm <sup>3</sup>				
UDL design load on rafter, w = P x Sraf = 0.60 kN/m = 40.8 Lb/ft							
Allowable bending stress, sp = Sp x k2 x k3 x k7 =		46.61	N/mm <sup>2</sup>				
Allowable bending strength Mp = sp x Sx =		7.1	kNm	(dressed size)			
Actual bending, M = wL <sub>raf</sub> <sup>2</sup> /8 =		7.1	kNm	use zone 2, as rafter length critical			
<b>Actual bending &lt; allowable bending strength, member size OK</b>							
Allowable shear stress, sv = Sv x k3 = 16.19 N/mm <sup>2</sup>							
Shear capacity, Sv = sv x (2/3. bd) =		68.38	kN	[Note: vmax = 3/2. v/bd]			
Actual shear on rafter, V = wL <sub>raf</sub> /2 =		2.90	kN =	652.6	lbs		
<b>Actual shear &lt; allowable shear strength, OK</b>							
<b>Timber purlins check:</b>							
Material to be same as rafter.							
Length of purlin, Lpur = rafter spacing =	0.42	m =	1.4	ft			
Let spacing of purlins, Spur =	<b>1</b>	m =	3.3	ft			
Effective wind area =	0.42	m <sup>2</sup> =	4.52	sq. ft			
Check timber purlin size:							
purlin depth, H =	<b>50</b>	mm x	width, B =	<b>50</b>	mm		
Dressed timber section, h =	44	mm x	width, b =	44	mm		
Material properties of timber:							
Bending parallel to grain, Sp =	27.3	N/mm <sup>2</sup>					
Shear parallel to grain, Sv =	9.3	N/mm <sup>2</sup>					
wet exposure coefficient, k2 =	0.9						
duration load factor, k3 =	1.75	for D + L + W in 3-sec gusts					
depth modification factor, k7 =	1.24	k7 = (300/h) <sup>0.11</sup> for beam depths <300mm					
Section modulus, Z = (1/6) x BH <sup>2</sup> =		20833.3	mm <sup>3</sup>				

Project:	<b>Hurricane Resistant Buildings</b>				Date:	<b>12-Jul-21</b>		
Engineer:	<b>Shalini Jagnarine-Azan</b>				Page:	<b>5</b>	of	<b>5</b>
Description:	<b>Gable Roof_180mph_Exposure B</b>							
Allowable shear stress, $sv = Sv \times k3 =$	16.19		N/mm <sup>2</sup>					
Shear capacity, $Sv = sv \times (2/3 \cdot bd) =$	20.89		kN		[Note: $v_{max} = 3/2 \cdot v/bd$ ]			
Actual shear on rafter, $V = wL_{pur}/2 =$	0.30		kN =		67.0			lbs
<b>Actual shear &lt; allowable shear strength, OK</b>								
<b>Instructions: How to use the spreadsheet</b>								
<b>Step 1:</b> Please change	roof width	and	timber stresses	in the calculation				
<b>Step 2:</b> Adjust the	rafter depth	in the calculation until		bending passes i.e. "Member size OK"				
<b>Step 3:</b> Copy the	rafter spacing	and	uplift	result in the calculation into the correct table below				
<b>Summary Results</b>								
<b>Gable Roof</b>	width =	15.3m (50ft)						
Min. pitch =	20degs	Exposure:		<b>B</b>				
50x50 purlins	Max. Spacing (mm)	1000		Uplift =	0.8kN (180lbs)			
Material:	Hardwood (higher strength)		Sp: 27.3MPa, Sv: 9.25MPa					
Rafter size depth x width	Spacing (mm)	Spacing (in)	Uplift Force (kN)	Uplift Force (lbs)				
150 x 50	600	24	3.47	780				
200 x50	1050	41	6.07	1365				
250 x 50	1630	64	9.42	2118				
Material:	Hardwood (higher strength)		Sp: 22.3 Mpa, Sv: 8.06 Mpa					
Rafter size depth x width	Spacing (mm)	Spacing (in)	Uplift Force (kN)	Uplift Force (lbs)				
150 x 50	490	19	2.83	636				
200 x50	860	34	4.97	1117				
250 x 50	1330	52	7.69	1729				
Exposure Category	<b>B</b>	Width	18.3m (60ft)					
50x50 purlins	Max. Spaci	1000		Uplift =	0.8kN (180lbs)			
Material:	Hardwood (higher strength)		Sp: 27.3MPa, Sv: 9.25MPa					
Rafter size depth x width	Spacing (mm)	Spacing (in)	Uplift Force (kN)	Uplift Force (lbs)				
150 x 50	420	17	2.9	652				
200 x50	730	29	5.05	1135				
250 x 50	1140	45	7.88	1771				